

Electric fryer



CME 418 FRI

8 L electric fryer - 8kW.

CE

- Fixed stainless steel embossed tank with cool zone.
- Drain valve.
- Oil collection tank.
- Thermostat 60/180°.
- Safety thermostat;
- Removable heating element unit.
- ON / OFF switch.
- Power supply: Three-phase 400 V.
- Supplied with a large basket.
- Option: single-phase 230 V (with supplement).

CME 418 FRI

L 400 – D 650 – H 900

AMBASSADE
DE BOURGOGNE

The Chef's Choice.

8 L electric fryer - 8kW

CME 418 FRI

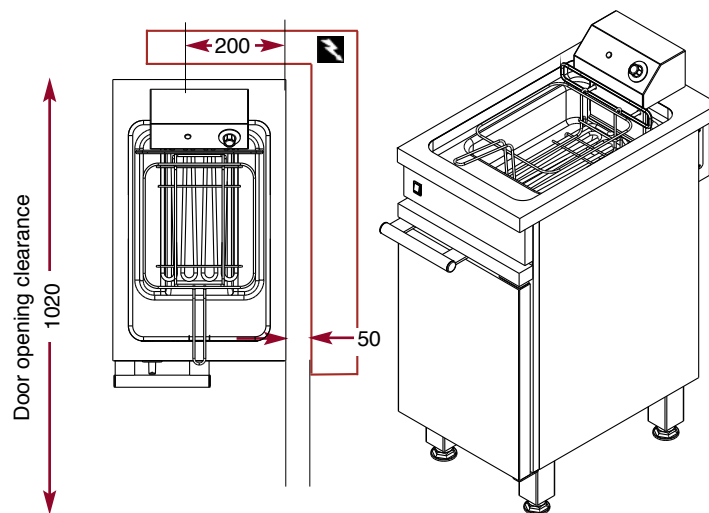
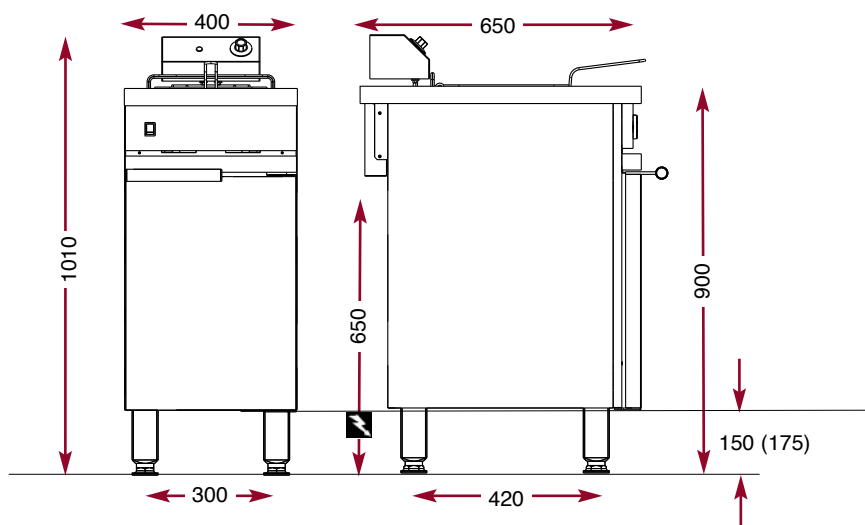

 Power connection

Hot zone complying with standards.

Large cool zone.

Embossed tank with rounded corners for easy maintenance and impeccable hygiene.

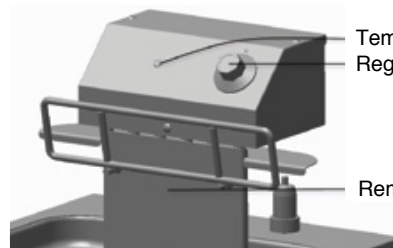
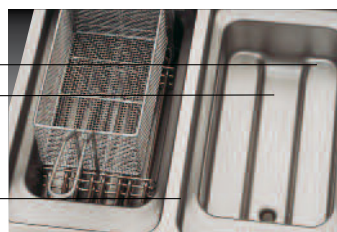

Temperature light indicator
Regulation thermostat

Removable eating element unit

Production capacity of electric fryers (*whitened, then browned continuously)

Appliance	Frozen fries*			Fresh fries*			Basket capacity (in g.)
	Cooking time (in mn)	Hour production (in kg)	Number of portions	Cooking time (in mn)	Hour production (in kg)	Number of portions	
E 418 FRI	5'00"	14,5	85	4'30"	16,5	94	1200

*The fryers are all equipped with a thermostat set to 180°C.



The Chef's Choice.